

DATE REVISED: 7/25/96

CATALOG NUMBER	"A" INTERFACE
A012-P93-09-T	FULL DETENT
A012-P94-09-T	LIMITED DETENT
A012-P95-09-T	SMOOTH BORE

MATERIAL AND FINISH

CENTER CONTACT: BeCu; GOLD PLATE 75 MICRONS TYPICAL
OVER NICKEL PLATE 100 MICRONS TYPICAL

HOUSING: BRASS; GOLD PLATE 75 MICRONS TYPICAL
OVER NICKEL PLATE 100 MICRONS TYPICAL

DIELECTRIC: POLYAMIDE-IMIDE

SOLDER DIP: SN 63 PB 37

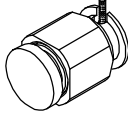

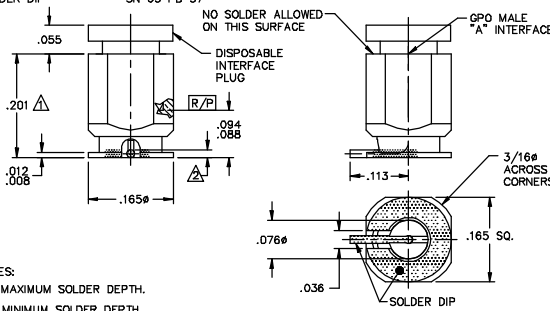

NO SOLDER ALLOWED ON THIS SURFACE

DISPOSABLE INTERFACE PLUG

GPO MALE "A" INTERFACE

3/16" ACROSS CORNERS

SOLDER DIP

NOTES:
 Δ MAXIMUM SOLDER DEPTH.
 ∇ MINIMUM SOLDER DEPTH.

RECOMMENDED MOUNTING FOOTPRINT

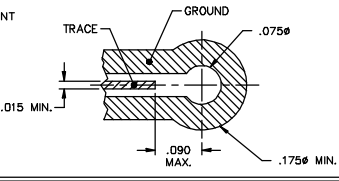

This drawing and any data contained herein is the property of Corning Gilbert Inc., and constitutes and contains proprietary and confidential information. Neither receipt nor possession of this drawing confers or transfers any right to duplicate, use or disclose any information contained herein except as expressly authorized by Corning Gilbert Inc.

GPO MALE (TAB DETENT) STRAIGHT TO COPLANAR LAUNCH SOLDER DIPPED	IDENT CODE: 82316 REVISION: A	Corning Gilbert Inc.
SOURCE FILE: SK-3426	DWG. NO.: QL-A012-P9X-09-T	ASSY. PROC.: -